

12

EUROPEAN PATENT APPLICATION

21 Application number: 80301358.0

51 Int. Cl.³: G 04 B 15/08

22 Date of filing: 25.04.80

30 Priority: 30.04.79 GB 7915006

43 Date of publication of application:
12.11.80 Bulletin 80/23

84 Designated Contracting States:
CH FR GB IT LI

71 Applicant: Daniels, George
21 Thornsett Road
London SE20 7XB(GB)

72 Inventor: Daniels, George
21 Thornsett Road
London SE20 7XB(GB)

74 Representative: Mayes, Stuart David et al,
BOULT, WADE & TENNANT 27 Furnival Street
London, EC4A 1PQ(GB)

54 Watches, clocks and chronometers and escapements therefor.

57 The invention relates to a detached escapement which preferably does not require oil to be applied to the escape wheel.

The escapement has an escape wheel (10;30), a balance wheel and a pivoted lever (14;37) arranged so that during each movement of the balance wheel in one direction of rotation an impulse is applied direct to an element (25;33) attached to the balance wheel. During each movement of the balance wheel in the other direction of rotation it is preferred that an impulse is applied to the balance wheel via the pivoted lever.

The escapement may be used in a watch, clock or chronometer.

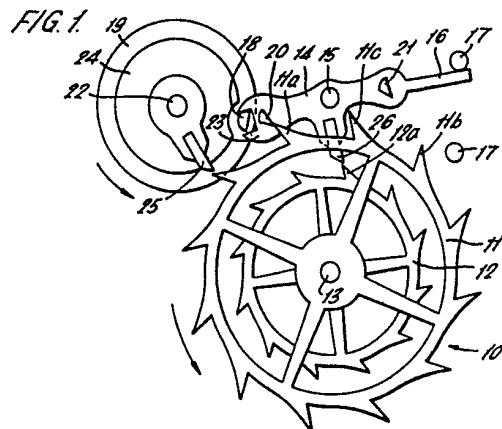

3/4

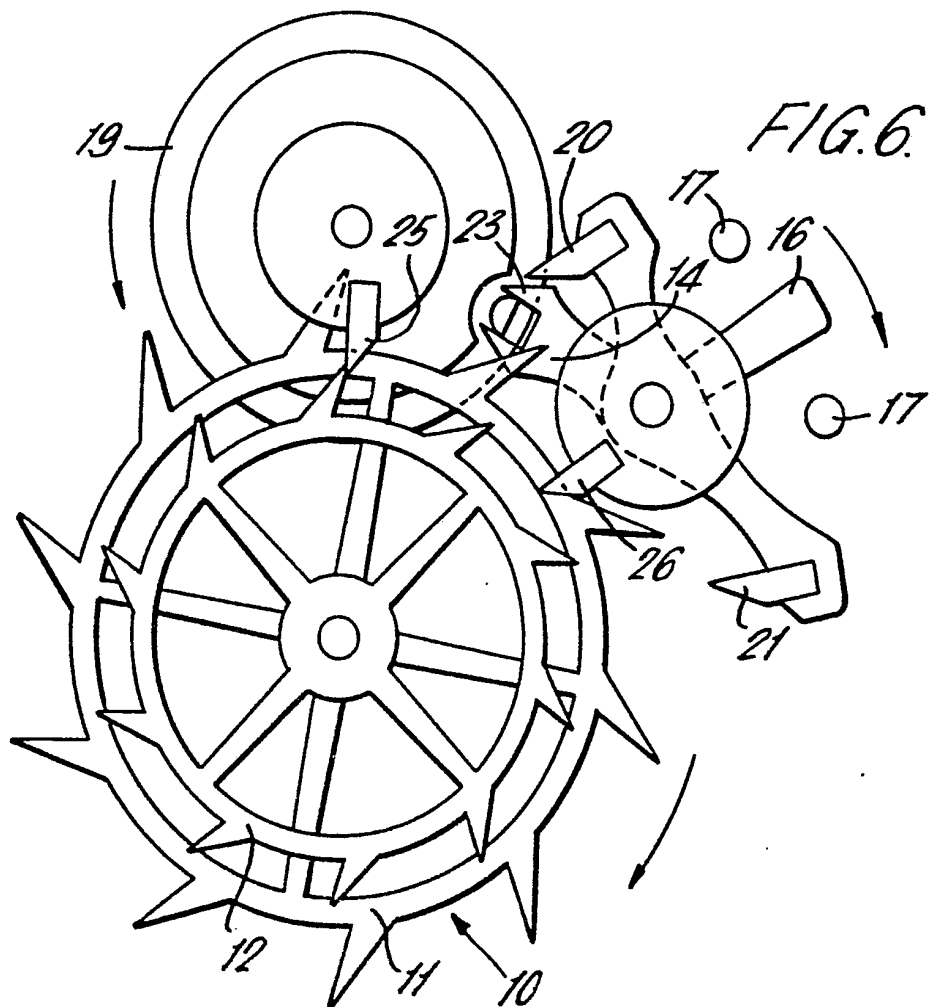
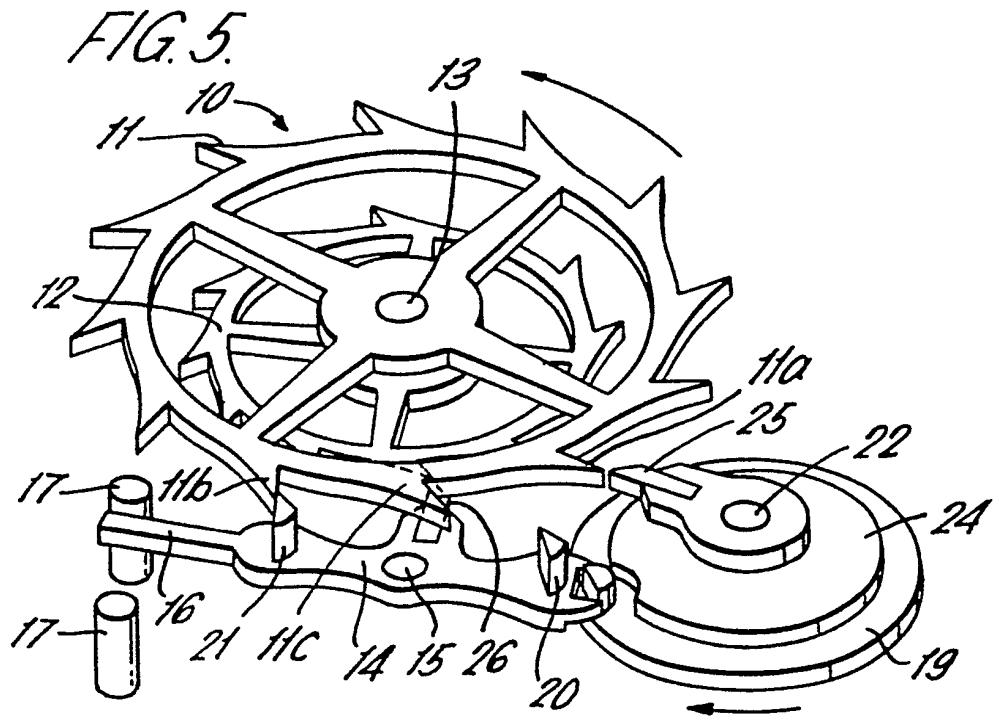
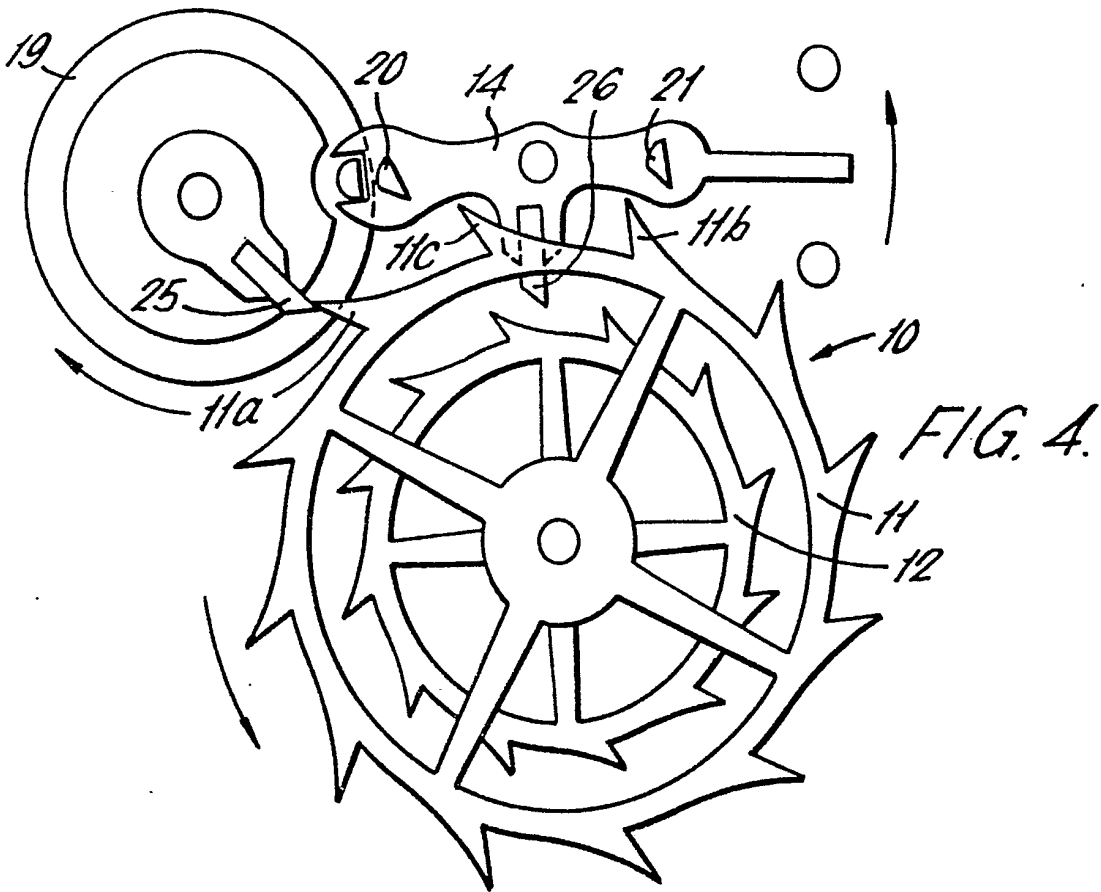
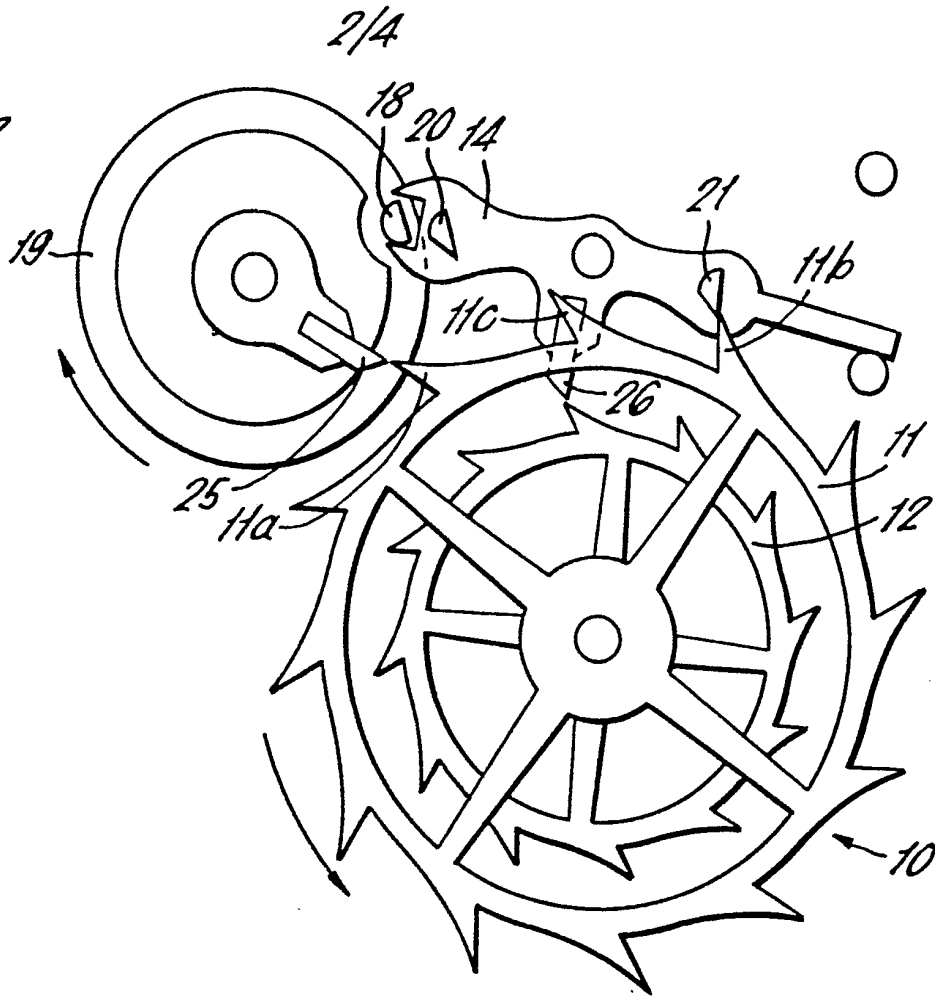
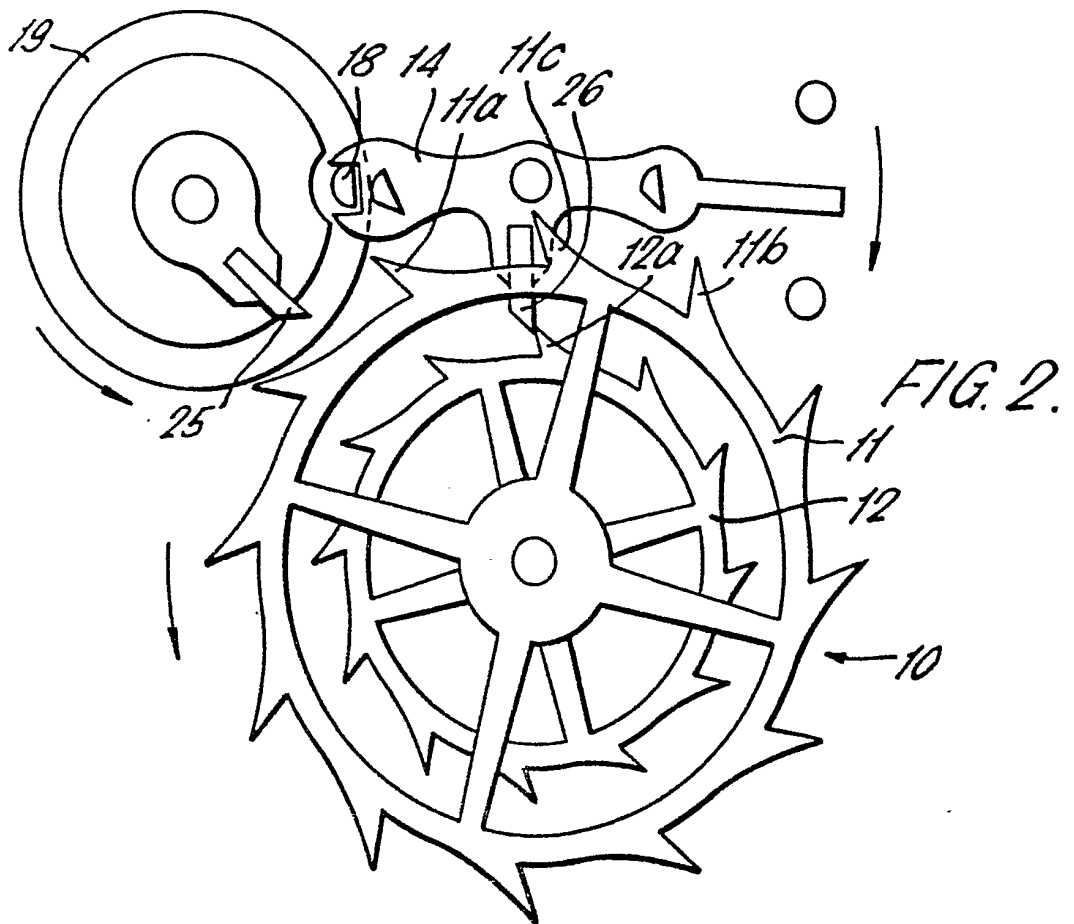
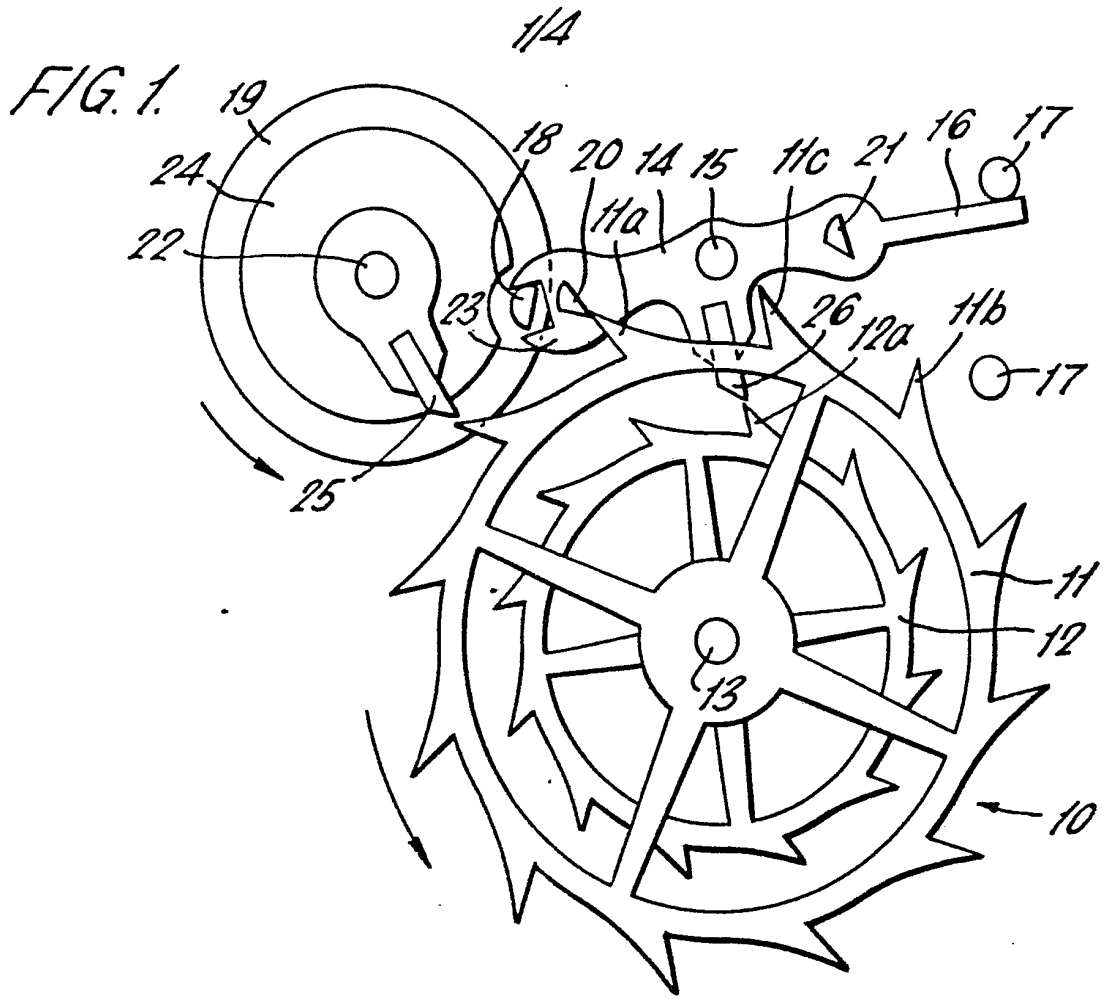

FIG. 3.





- 15 -

12. An escapement as claimed in any one of claims 1 to 8, wherein the escape wheel (30) has a single ring of teeth (11) which are both engaged by the pivoted lever (37) to lock the escape wheel
5 intermittently and to apply said impulses to the balance wheel.

13. An escapement as claimed in any one of the preceding claims, wherein the interengaging means between
10 the balance wheel and the lever are a pin (18;35) associated with the balance wheel which engages in a fork (23;38) in the lever (14;37).

14. An escapement as claimed in Claim 13, wherein
15 the pin (35) is mounted on the balance arm (36).

15. A watch, clock or chronometer having an escapement as claimed in any one of the preceding claims.

RESH/KS

- 14 -

8. An escapement as claimed in any one of the preceding claims, wherein the area of surface contact of the wheel teeth (11) is sufficiently small that oil is not required to be applied to the escape wheel (10;30).

5

9. An escapement as claimed in claim 3, wherein the escape wheel (10) has two concentric rings of teeth (11;12) of different radii disposed in parallel planes.

10

10. An escapement as claimed in claim 9, wherein the outer ring of teeth (11) of the escape wheel (10) are engaged by the pivoted lever (14) to lock the escape wheel intermittently and to apply each said impulse which is applied direct to an element (25) attached to the balance wheel, whilst the inner ring of teeth (12) of the escape wheel apply each said impulse which is applied to the balance wheel via the pivoted lever.

20

11. An escapement as claimed in claim 9, wherein the outer ring of teeth (11) of the escape wheel are engaged by the pivoted lever (14) to lock the escape wheel intermittently, and the inner ring of teeth (12) apply said impulses to the balance wheel.

25

- 13 -

other direction of rotation the impulse is applied to the balance wheel via the pivoted lever (14;37).

4. An escapement as claimed in claim 3, wherein
5 the pivoted lever (14;37) carries an impulse pallet (26;34) for engagement by a tooth (12;11) of the escape wheel during each movement of the balance wheel in said other direction of rotation.

10 5. An escapement as claimed in any one of claims 2 to 4, wherein the surface of the or each impulse pallet (25, 26; 33, 34) when engaged by a tooth (11;12) of the escape wheel (10;30) is radial of the escape wheel.

15

6. An escapement as claimed in any one of the preceding claims, wherein the pivoted lever (14;37) is mid-way between banking pins (17) during the application of each impulse to the balance wheel.

20

7. An escapement as claimed in any one of the preceding claims, wherein the pivoted lever (14;37) carries entry and exit locking pallets (21, 20; 31, 32) for alternate engagement with a tooth (11) of the escape
25 wheel (10;30).

CLAIMS

1. A detached escapement comprising a toothed
escape wheel (10;30) urged to rotate in a single direction
5 by a mainspring and intermittently held against rotation
by a pivoted lever (14;37), and a balance wheel arranged
to be oscillated by a balance spring, interengaging means
(18,25;35,38) between the balance wheel and the lever
whereby during each movement of the balance wheel the
10 lever is pivoted to release the escape wheel to move
through half a tooth, during which movement of the
escape wheel the balance wheel receives an impulse from
the escape wheel, characterised in that during each
movement of the balance wheel in one direction of
15 rotation the impulse is applied direct to an element (25;33)
attached to the balance wheel.

2. An escapement as claimed in claim 1, wherein
an impulse pallet (25;33) is attached to the balance
20 wheel for oscillation therewith, the pallet being engaged
by a tooth (11;12) of the escape wheel during each move-
ment of the balance wheel in said one direction of rotation.

3. An escapement as claimed in claim 1 or claim 2,
25 wherein during each movement of the balance wheel in the

with its tail mid-way between the banking pins.
Hence, in this condition, the escape wheel will
always be unlocked and one tooth of the escape wheel
will be in engagement with one of the impulse pallets,
5 whereby the application of power to the escape wheel,
i.e. by winding the mainspring, will cause that tooth
to impulse the respective pallet and the escapement
will start the balance wheel oscillating without it
being necessary to shake or agitate the watch, clock
10 or chronometer. Thus the escapement is self-starting
from the unwound condition.

Additionally if the escapement is stopped
accidentally, the escapement will still be self-
starting even though a tooth of the escape wheel may
15 be locked by one of the locking pallets. This is
because the energy stored in the balance spring when
the balance spring is not quiescent or mid-way
through its oscillating cycle, is sufficient to unlock
the escape wheel from the locking pallet.

wheel (not shown). . Consequently, the pivoted lever 37 has its forked end 38 cranked for engagement with the pin 35, the escapement thereby taking up considerably less space vertically compared with the escapements of Figures 1 to 5 and Figure 6. This may be important when it is desired to incorporate the escapement in a watch. However, the manner of operation of the escapement is entirely similar to the embodiments previously described.

In the case of the embodiment of Figures 1 to 5, the escape wheel 10 as viewed in the drawings is driven by the mainspring in an anti-clockwise direction, whereas in the embodiments of Figures 6 and 7 the escape wheel is shown as being driven in a clockwise direction. However, in the case of each embodiment, the escape wheel 10 can be arranged to rotate in either direction, whichever is desired. Similarly, the lever 14 may be pivotally mounted on either side of the line joining the axes of the balance and escape wheels. There is thus provision for considerable flexibility of design layout.

In each embodiment, when the balance wheel and balance spring are quiescent because the mainspring is run down, the lever 14 or 37 will be positioned

- 9 -

and the above cycle repeated.

The fact that when the balance wheel is moving in a clockwise direction the impulse is applied via the balance impulse pallet 25, and that during movement in the other direction of rotation the impulse is applied via the lever impulse pallet 26 and the lever 14 means that during each oscillation secure intersection of the impulse components is achieved.

It will also be appreciated that in the embodiment described above, one impulse is applied by an outer tooth 11 of the escape wheel and the next impulse is applied by an inner tooth 12 of the escape wheel. In another embodiment of escapement shown in Figure 6, both impulses are applied by an inner tooth 12 of the escape wheel. Otherwise the escapement operates in the same manner as before and the same reference numerals are employed.

Figure 7 illustrates a further embodiment in which the escape wheel 30 is a single wheel in which the same teeth engage the entry and exit locking pallets 31, 32 and the impulse pallets 33, 34. A further difference is that the balance roller is omitted and the balance roller pin 35 is mounted on the balance arm 36 which forms a part of the balance

- 8 -

described. In the condition shown in Figure 1, the escape wheel 10 is held against rotation by engagement of tooth 11a with the exit locking pallet 20. Rotation of the balance wheel and hence the balance roller 19 in an anti-clockwise direction causes engagement of the balance roller pin 18 with the fork 23 of the lever 14 and thereby pivotal movement of the lever to release the escape wheel. The escape wheel then rotates through half a tooth until it is stopped by the entry locking pallet 21 engaging tooth 11b (Figure 3). In the meantime the tooth 12a has engaged the pallet 26 to apply an impulse via the lever 14 to the balance wheel 19 (Figure 2). The balance wheel will continue to rotate in the anti-clockwise direction until the energy is exhausted.

The energy stored in the balance spring will then reverse the direction of rotation of the balance wheel and the balance roller pin 18 will again engage the fork 23 of the lever 14 (Figure 3). The lever 14 will pivot to release tooth 11b from the entry locking pallet 21 and the escape wheel will again rotate until tooth 11c engages the exit locking pallet 20. In the meantime tooth 11a has engaged the pallet 25 to apply an impulse to the balance wheel (Figure 4). The direction of rotation of the balance wheel will then again be reversed

- 7 -

viewed in Figure 4. An impulse is thereby applied by the escape wheel to the balance wheel. When the balance wheel is moving in the opposite direction of rotation an impulse is applied to the balance wheel through engagement of an inner tooth 12 of the escape wheel and another pallet 26 carried by the lever 14 (Figure 2).

In this embodiment the areas of contact between the locking pallets 20, 21 and the teeth of the escape wheel, and also between the impulse pallets 25, 26 and the teeth of the escape wheel, are sufficiently small that no oil is required. Also, in this embodiment, the position of the balance impulse pallet 25 relative to the balance staff 22 and the outer teeth 11 of the escape wheel, and similarly the position of the lever impulse pallet 26 relative to the arbor 15 and the inner teeth 12 of the escape wheel, is chosen so that the impulse applied to the balance wheel through each pallet is of the same strength. Moreover, both impulses are applied radially of the escape wheel, i.e. the teeth of the escape wheel engage the pallets 25, 26 when the surfaces of the pallets engaged by the teeth of the escape wheel are radial of the escape wheel (see Figures 2 and 4).

The operation of the escapement will now be

- 6 -

wheel, for example a wheel of which the inner ring of teeth project downwardly into a plane beneath the outer ring of teeth.

The lever 14 is mounted for pivotal movement about an arbor 15 and at one end has a tail 16 which extends between two banking pins 17 which limit the extreme positions of the lever. The other end of the lever 14 is formed at 23 for reception of the balance roller pin 18. In this embodiment the balance roller pin is carried by the balance roller 19 which is itself attached to the balance wheel (not shown). The lever 14 carries exit and entry locking pallets 20, 21 respectively for alternate engagement with an outer tooth 11 of the escape wheel when the lever is in its respective extreme position, the escape wheel thereby being held against rotation (Figures 1, 3 and 5).

The balance roller 19 is mounted for oscillation about a staff 22 and carries a conventional safety roller 24 which prevents the lever 14 from pivoting when the balance roller pin 18 is not engaged within the fork 23 of the lever, and also a pallet 25 for engagement by an outer tooth 11a of the escape wheel (see Figure 4) when the balance wheel is moving in the appropriate direction of rotation, i.e. clockwise as

- 5 -

Figure 4 shows the escapement in the condition of Figure 3 but at mid-impulse;

Figure 5 is a perspective view of the escapement in the condition of Figure 3;

Figure 6 is a plan view of another escapement in a condition similar to Figure 4; and

Figure 7 is a perspective view of a further escapement in a condition similar to Figure 3.

10 This example relates to a watch, clock or chronometer escapement having a toothed escape wheel urged to rotate in a single direction by a mainspring via a gear train and intermittently held against rotation by a pivoted lever. The escapement also has a
15 balance wheel arranged to be oscillated by a balance spring. The invention is concerned only with the escape wheel, the pivoted lever and the balance wheel and so only these parts will be described.

20 Referring to Figures 1 to 5, the escape wheel 10, has two concentric rings of teeth 11, 12 disposed in parallel planes, one above the other. In this embodiment the teeth are provided by two wheels of different radii mounted for rotation together on the
25 same arbor 13 but may readily be provided by a single

- 4 -

The invention also provides a watch, clock or chronometer having an escapement as defined above.

By way of example, specific embodiments in accordance with the invention will be described with reference to the accompanying diagrammatic drawings
5 in which:-

Figure 1 is a plan view of an escapement for a watch, clock or chronometer, the balance wheel shown rotating in an anti-clockwise direction and about to
10 unlock the escape wheel;

Figure 2 shows the escapement of Figure 1 at mid-impulse;

Figure 3 shows the condition of the escapement of Figure 1 in which the balance wheel is rotating
15 in the opposite direction and about to unlock the escape wheel;

each movement of the balance wheel.

Preferably the pivoted lever carries an impulse
pallet for engagement by a tooth of the escape wheel
during each movement of the balance wheel in said other
5 direction of rotation.

The surface of the or each impulse pallet when
engaged by a tooth of the escape wheel is preferably
radial of the escape wheel.

The pivoted lever is preferably arranged so that
10 it is mid-way between banking pins during the application
of each impulse to the balance wheel.

The pivoted lever also preferably carries entry and
exit locking pallets for alternate engagement with a
tooth of the escape wheel.

15 Preferably the area of surface contact of the
escape wheel teeth is sufficiently small that oil is
not required to be applied to the escape wheel.

The escape wheel may have two concentric rings
of teeth of different radii disposed in parallel planes
20 Alternatively, the escape wheel may have a single ring
of teeth.

Preferably the interengaging means between the
balance wheel and the lever are a pin associated with the
balance wheel which engages in a fork in the lever. The
25 pin may be mounted on the balance arm.

- 2 -

oil is not required.

According to the invention there is provided a detached escapement which requires no oil comprising a toothed escape wheel, pivoted lever and balance wheel as described above except that during each oscillation of the balance wheel in one direction the impulse from the escape wheel to the balance wheel is transmitted via the pivotal lever and during each oscillation of the balance wheel in the other direction the impulse from the escape wheel to the balance wheel is transmitted direct to the balance wheel or an element attached thereto. This difference has the advantage that the direction of rotation of the escape wheel may be opposite to the direction of pivotal movement of the lever when the balance wheel oscillates in said one direction and opposite to the direction of rotation of the balance wheel when the balance wheel oscillates in the other direction. In this case, the secure intersection of the impulse transmitting components may be achieved during each oscillation of the balance wheel.

Preferably the impulse transmitted to the balance wheel each time it oscillates in said other direction is transmitted from a tooth of the escape wheel to a pallet attached to the balance wheel.

WATCHES, CLOCKS AND CHRONOMETERS
AND ESCAPEMENTS THEREFOR

The invention relates to watches, clocks and
5 chronometers and escapements therefor.

It is known to provide a detached escapement
comprising a toothed escape wheel urged to rotate in
a single direction by a mainspring via a gear train
and intermittently held against rotation by a pivoted
10 lever, and a pin forming part of a balance wheel
which is arranged to be oscillated by a balance spring.
During each movement of the balance wheel the pin
moves the lever in the opposite direction which
releases the escape wheel to move through half a tooth,
15 and the balance wheel receives an impulse from a tooth
of the escape wheel via the pivoted lever.

According to the invention there is provided a
detached escapement comprising a toothed escape wheel
urged to rotate in a single direction by a mainspring
20 and intermittently held against rotation by a pivoted

FIG. 7.

